

Spannsatz

optional
chem. vernickelt
optional komplett
in Edelstahl

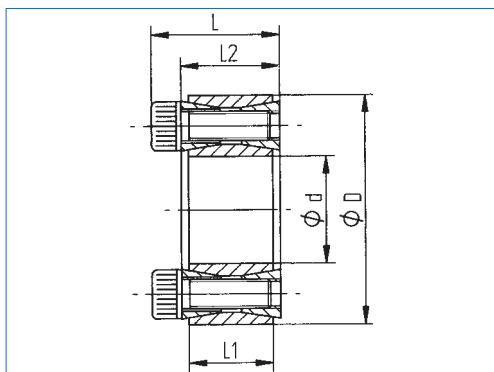

übertragbares Drehmoment	mittel
Flächenpressung auf der Nabe	hoch
selbstzentrierend	nein
Axialverschiebung der Nabe während der Montage	nein
Bauhöhe D/d	hoch
Baulänge	kurz

Bestellbeispiel

KBS 40 - 75 x 115

Typ Ød ØD

Die empfohlenen Bearbeitungstoleranzen für die Druckflächen sind: Welle h11 / Nabe H11

Innen / Außen Ø dxD	Drehmoment T Nm	Abmessungen			Flächenpressung an		Spannschrauben			Gewicht kg
		L mm	L1 mm	L2 mm	Welle Pw N/mm ²	Nabe Pn N/mm ²	St.	ISO 4762	TA Nm	
19 x 47	255	28	17	20	220	90	8	M6x18	14	0.20
20 x 47	270	28	17	20	210	90	8	M6x18	14	0.20
22 x 47	300	28	17	20	195	90	8	M6x18	14	0.20
24 x 50	360	28	17	20	195	95	9	M6x18	14	0.23
25 x 50	380	28	17	20	190	95	9	M6x18	14	0.21
28 x 55	500	28	17	20	187	96	10	M6x18	14	0.25
30 x 55	530	28	17	20	176	96	10	M6x18	14	0.26
32 x 60	630	28	17	20	192	105	12	M6x18	14	0.27
35 x 60	700	28	17	20	180	105	12	M6x18	14	0.28
38 x 65	860	28	17	20	183	107	14	M6x18	14	0.30
40 x 65	910	28	17	20	180	110	14	M6x18	14	0.30
42 x 75	1500	32	20	24	226	125	12	M8x22	35	0.55
45 x 75	1610	32	20	24	210	125	12	M8x22	35	0.56
48 x 80	1700	32	20	24	196	115	12	M8x22	35	0.57
50 x 80	1770	32	20	24	190	115	12	M8x22	35	0.58
55 x 85	2270	32	20	24	200	130	14	M8x22	35	0.60
60 x 90	2470	32	20	24	180	120	14	M8x22	35	0.65
65 x 95	3040	32	20	24	190	130	16	M8x22	35	0.70
70 x 110	4600	38	24	28	210	130	14	M10x25	70	1.25
75 x 115	4900	38	24	28	195	125	14	M10x25	70	1.30
80 x 120	5200	38	24	28	180	120	14	M10x25	70	1.35
85 x 125	6300	38	24	28	195	130	16	M10x25	70	1.45
90 x 130	6600	38	24	28	180	125	16	M10x25	70	1.53
95 x 135	7900	38	24	28	195	135	18	M10x25	70	1.62
100 x 145	9600	47	26	33	195	135	14	M12x30	125	2.10
110 x 155	10500	47	26	33	180	125	14	M12x30	125	2.25
120 x 165	13100	47	26	33	185	135	16	M12x30	125	2.45
130 x 180	17600	50	34	38	165	115	20	M12x35	125	3.45
140 x 190	20900	50	34	38	165	125	22	M12x35	125	3.65
150 x 200	24200	50	34	38	170	125	24	M12x35	125	3.90
160 x 210	28000	50	34	38	170	130	26	M12x35	125	4.45
170 x 225	32800	60	38	44	160	120	22	M14x40	190	5.45
180 x 235	37800	60	38	44	165	125	24	M14x40	190	6.05
190 x 250	46500	68	46	52	150	115	28	M14x45	190	8.25
200 x 260	52500	68	46	52	150	115	30	M14x45	190	8.65
220 x 285	68000	74	50	56	150	115	26	M16x50	295	11.15