

Metallbalgkupplung

längenverstellbare Ausführung

optional
lasergeschweißt
optional komplett
in Edelstahl



KBK

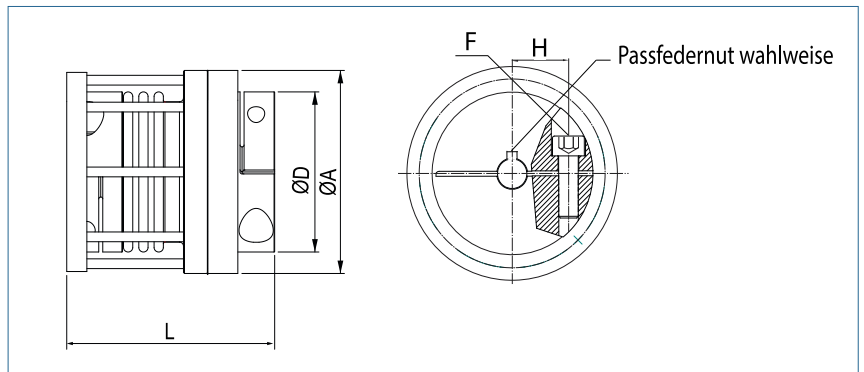

Bestellbeispiel

KB4LV / 60 - 87 - 12 - 32 - (S)

Typ / Größe

Länge
L

ØD1
(H7)

ØD2
(H7)

Optionen

Größe	Drehmoment TKN (Nm)	Abmessungen (mm)									Technische Daten								
		L Länge	L1 max. Länge	Ø D Nabendurchmesser	Ø A Außendurchmesser	D1/D2 Bohrungen (H7) von-bis	H	C	E	F Schraube ISO4762 TA (Nm)	Masse (kg)	Massenträgheitsmoment J (g m²)	Federsteifigkeit			Versatz			max Drehzahl min-1
													Torsion CT 10³ (Nm/rad)	radial CR (N/mm)	axial CA (N/mm)	radial ΔKr (mm)	axial ΔKa (mm)	Winkel ΔKw (°)	
18	18	69.5	100	45	63	10-25.4	17	5.5	17.5	M5 8	0.25	0.15	35	3350	97	0.1	0.5	0.5	12800
30	30	82.5	115	56	74	10-32 30#	20	7.3	21	M6 15	0.5	0.37	53	6436	165	0.1	0.5	0.5	10300
60	60	87	120	66	86	12-35	24	8.6	24	M8 40	0.78	3.88	138*	12442	287	0.15	1	0.5	8700
150	150	102	150	82	104	14-44	28	9.8	27	M10 84	1.1	1.56	176	6815	338	0.15	1	0.5	6900
300	300	119	179	110	132	20-60	40	11.8	32.5	M12 145	2.2	5.32	579	29096	756	0.15	1.5	1	6000
500	500	129.5	190	122	155	25-70	42	13.3	36	M12 145	3.25	10.14	693	20694	639	0.15	1.5	1	5000



Material	Balg - Edelstahl Nabe - Aluminium
Nabe	Bohrungstoleranz: H7
Temperaturbereich	-30 °C ~ 120 °C
Passfedernut	wahlweise nach DIN 6885 größtmögliche Bohrung mit # gekennzeichnet * Ausführung: 2-Wellen-Balg

