

Metallbalgkupplung
axial steckbar, mit Außenkonus

optional
lasergeschweißt
optional komplett
in Edelstahl

KB6P

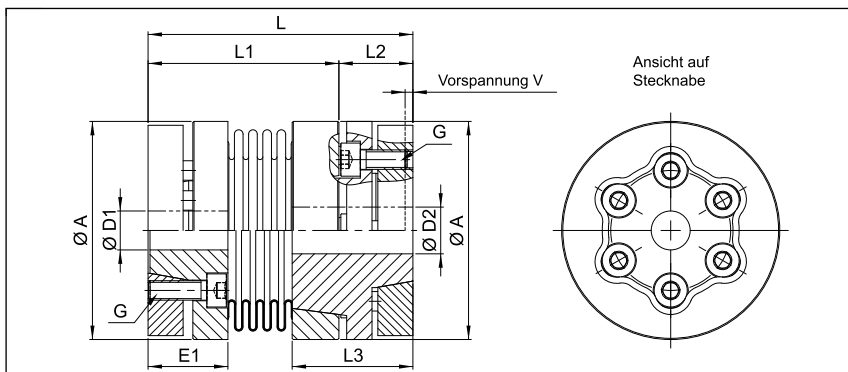

Bestellbeispiel

KB6P / 60 - 79 - 20 - 15 - D - (S)

Typ / Größe Länge L ØD1 (H7) ØD2 (H7) Steckung Optionen

Größe	Drehmoment TKN (Nm)	Abmessungen (mm)					Technische Daten									
		L Länge	Ø A Außen- durch- messer	Ø D1 Bohrung (H7) von-bis	Ø D2 Bohrung (H7) von-bis	E1	G Schraube (ISO4762) TA (Nm)	Masse (kg)	Massenträg- heitsmoment J (g m²)	Federsteifigkeit			Versatz			max. Drehzahl (min-1)
									Torsion CT 10³ (Nm/rad)	radial CR (N/mm)	axial CA (N/mm)	radial ΔKr (mm)	axial ΔKa (mm)	Winkel ΔKw (°)		
18	18	67	45	8-14	10-22	20.5	M4	0.4	0.1	20	205	50	0.2	0.5	1.5	12800
		75					4.3	0.45	0.11	15	82	36	0.25	0.5	2	
30	30	68	56	10-24	10-24	22	M5	0.48	0.16	38	720	50	0.15	0.6	1.5	10300
		76					6.5	0.5	0.18	28	225	28	0.25	1.0	2	
60	60	79	66	12-32	12-32	24	M5	0.88	0.38	75	1150	90	0.15	0.6	1.5	8700
		89					8	0.98	0.41	50	340	50	0.25	1.0	2	
150	150	97	82	15-40	15-40	35	M6	1.6	1.8	155	2020	145	0.2	0.5	1.5	6900
		108					12	1.69	1.85	105	595	85	0.25	0.8	2	
300	300	113	110	24-56	24-56	35	M8	2.28	4.05	502	6300	280	0.2	0.5	1.5	6000
		125					30	2.38	4.25	285	1400	145	0.25	0.8	2	
500	500	133	122	30-60	30-60	40	M8	3.8	7.55	690	7790	100	0.2	0.5	1.5	5000
		144					32	3.9	7.75	320	970	85	0.25	1.0	2	

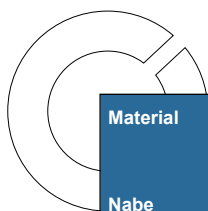

Material	Balg - Edelstahl Naben - Aluminium Spannringe - Stahl
Nabe	Bohrungstoleranz: H7
Temperaturbereich	-30 °C ~ 120 °C

Größe	Abmessungen (mm)			
	L1	L2	L3	V
18	52	15	22	0.5-1.0
	60			
30	51.5	16.5	31	0.5-1.0
	59.5			
60	57	22	35	0.5-1.5
	67			
150	73	24	37.5	0.5-1.5
	84			
300	82	31	48	0.5-1.5
	93			
500	90	43	64	0.5-2.0
	101			

