

Metallbalgkupplung

axial steckbar, mit Klemmnabe

optional
lasergeschweißt
optional komplett
in Edelstahl

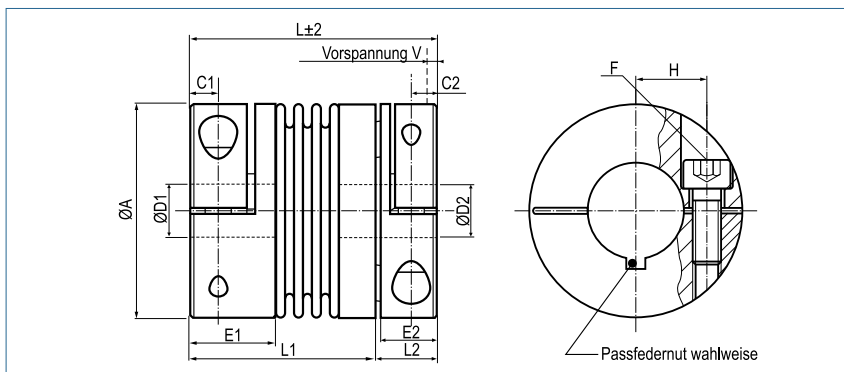
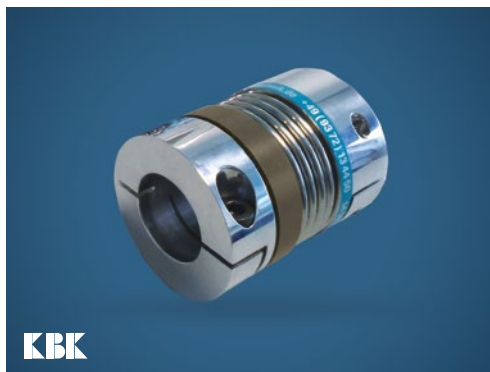

Bestellbeispiel

KB4P / 150 - 95 - 44 - 28 - D - (S)

Typ / Größe Länge L ØD1 (H7) ØD2 (H7) Steckung Optionen

Größe	Drehmoment TKN (Nm)	Abmessungen (mm)										Technische Daten								
		Länge	Ø A	D1/D2	H	C1	C2	E1	E2	B	F	Schraube (ISO4762) TA (Nm)	Masse (kg)	Massenträgheitsmoment J (g m²)	Torsion CT 10³ (Nm/rad)	radial CR (N/mm)	axial CA (N/mm)	radial ØKr (mm)	axial ØKa (mm)	Winkel ØKw (°)
18	18	62	45	10-24	17	5.5	5.5	17.5	12	47.4	M5	0.14	0.05	20	205	50	0.2	0.5	1.5	12800
		70									8	0.19	0.06	15	82	36	0.25	0.5	2	
30	30	73	56	10-30	20	7.5	7.3	24.5	17	56.4	M6	0.29	0.14	38	720	50	0.15	0.6	1.5	10300
		81									15	0.31	0.15	28	225	28	0.25	1.0	2	
60	60	85	66	12-35	23	10	8.6	29	21	66	M8	0.47	0.33	75	1150	90	0.15	0.6	1.5	8700
		95									40	0.57	0.36	50	340	50	0.25	1.0	2	
80	80	95	82	12-44	28	11	9.8	33.5	21.5	82.9	M10	0.81	0.89	128	1200	80	0.2	0.5	1.5	6900
		106									84	0.90	0.99	75	400	50	0.25	0.8	2	
150	150	95	82	14-44	28	11	9.8	33.5	21.5	82.9	M10	0.91	1.08	155	2020	145	0.2	0.5	1.5	6900
		106									84	1.00	1.18	105	595	85	0.25	0.8	2	
200	200	105	90	16-47	39	13	10.8	38	24	90.8	M12	1.16	1.47	175	2500	145	0.2	0.5	1.5	6400
		117									125	1.26	1.67	120	460	82	0.25	0.8	2	
300	300	114	110	20-60	39	13	10.8	38	27	110	M12	1.68	3.33	502	6300	280	0.2	0.5	1.5	6000
		125									145	1.78	3.53	285	1400	145	0.25	0.8	2	
500	500	136	122	25-70	45	15	13.3	42	42	122	M12	2.50	6.21	690	7790	100	0.2	0.5	1.5	5000
		147									145	2.60	6.41	320	970	85	0.25	1.0	2	

Material	Balg – Edelstahl Nabe - hochfestes Aluminium
Nabe	Bohrungstoleranz: H7
Passfedernut	wahlweise nach DIN 6885
Temperaturbereich	-30 °C ~ 120 °C

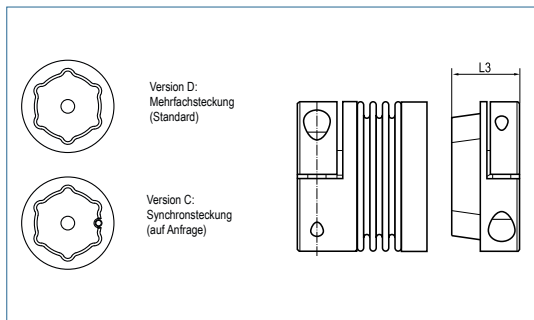

Größe	Abmessungen (mm)			
	L1	L2	L3	V
18	48	14	22	0.5-1.0
	56			
30	54	19	31	0.5-1.0
	62			
60	62	23	35	0.5-1.5
	72			
80	71.5	23.5	37.5	0.5-1.5
	82.5			
150	71.5	23.5	37.5	0.5-1.5
	82.5			
200	79	26	42	0.5-1.5
	91			
300	85	29	47	0.5-1.5
	96			
500	92	44	66	0.5-2.0
	103			