

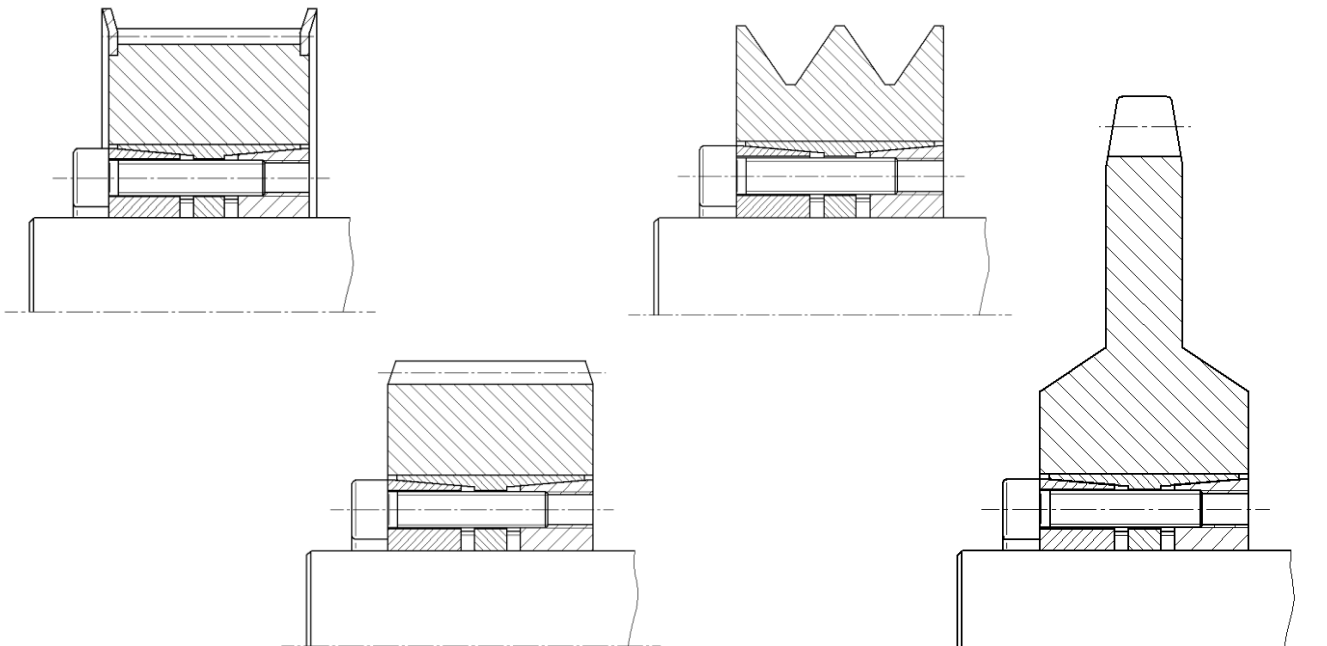

# Locking Device KBS 18

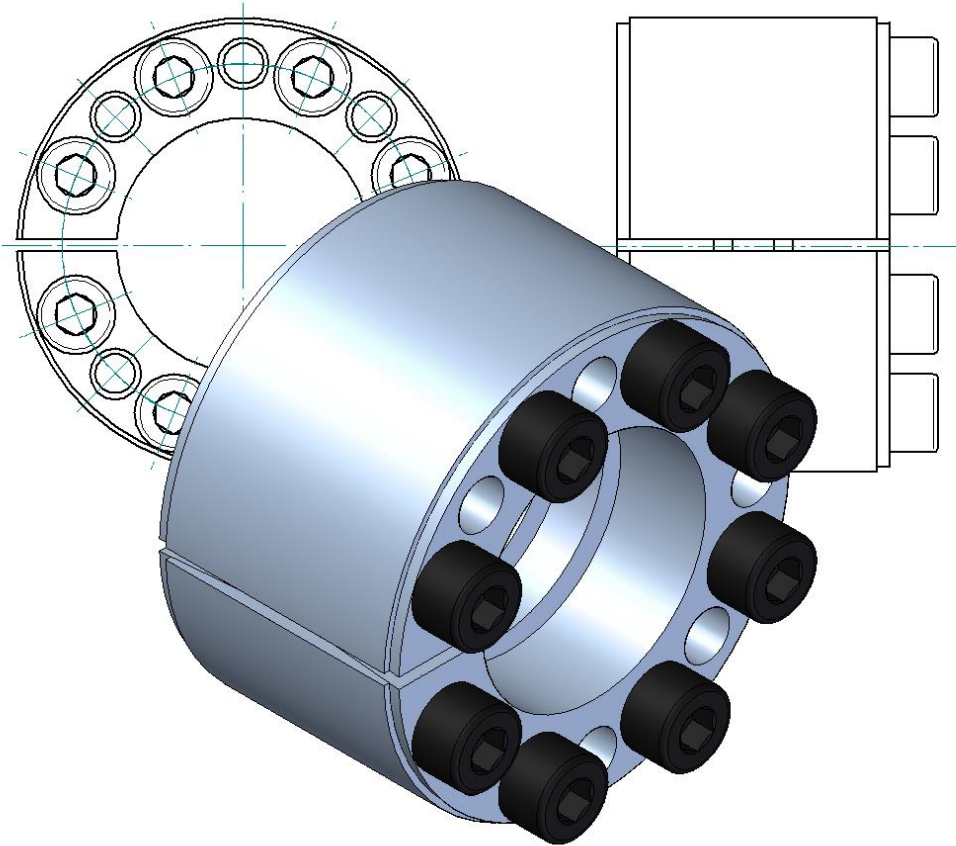

**KBS 18 Locking Device** is a frictionally engaged detachable shaft-hub connection for cylindrical shafts and bores without keyway.





**Features**

- delivered in mounted condition
- self-centering
- concentricity **0,02 – 0,04 mm**

***Tolerances, Surfaces***

- a good turning process is sufficient: **Rz ≤ 16 µm**
- maximum tolerance: **d = h8/H8 – shaft/hub**

**Components of the locking device KBS 18**

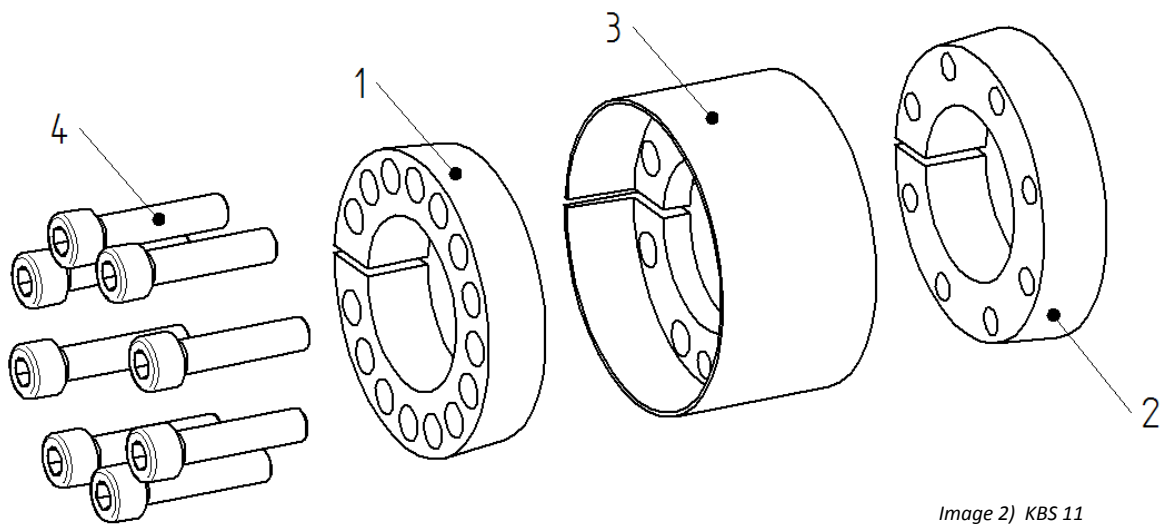

Image 2) KBS 11

Component	Quantity	Description
1	1	front pressure ring (slotted)
2	1	rear pressure ring (slotted)
3	1	external ring (slotted)
4	see catalogue	socket head screw DIN EN ISO 4762



**Information!**

Contaminated or used locking devices have to be detached and cleaned prior to installation. Then apply a thin layer of low viscosity oil (e.g. Ballistol all-purpose oil or Klüber Quietsch-Ex).





**Assembly of the locking device**

- Check shaft- and hub-position regarding the stipulated tolerance (h8/H8).
- Contact surfaces of locking device as well as contact surfaces of shaft and hub have to be cleaned (see image 4). Then apply a thin layer of low viscosity oil (e.g. Ballistol Öl or Klüber Quietsch-Ex).

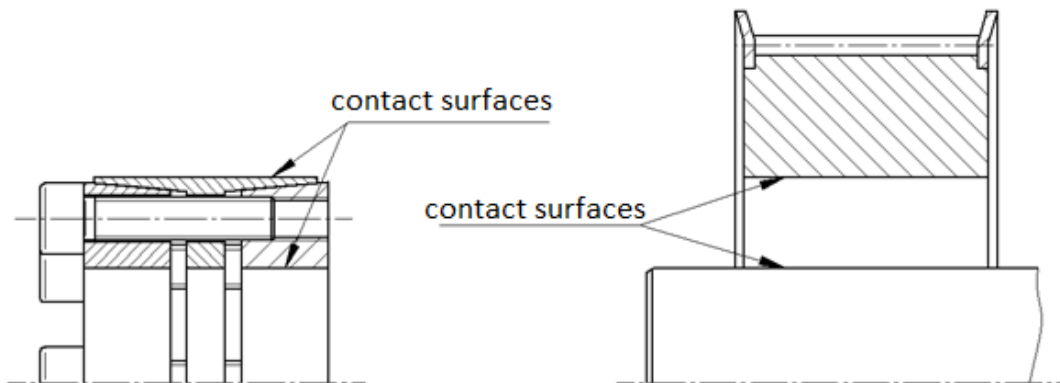

Image 3) cleaning the contact surfaces



**ATTENTION!**

Do not use any oil, grease or sliding-grease paste reducing the coefficient of friction significantly. Oil-free assembly of the locking device may result in different values shown in the table and the values calculated.

- Slightly loosen the clamping screws. Then insert the locking device KBS 18 between shaft and hub.
- Slightly tighten the clamping screws manually and align the locking device with the hub.
- Tighten clamping screws crosswise and evenly in several turns with the tightening torque specified in table 1. Repeat this procedure until a 1/4-turn is no longer possible. Then tighten the clamping screws in sequence according to the specified tightening torque.

**Table 1:**

Locking Device	KBS 18						
	M6	M8	M10	M12	M14	M16	M20
Thread Size M	M6	M8	M10	M12	M14	M16	M20
Tightening Torque T <sub>A</sub> [Nm]	17	41	83	145	230	355	690



**Information!**

Assembly of the KBS 18 may result in an axial displacement between hub and shaft.



## Disassembly of the locking device



**DANGER!**

Loosened or falling drive components may result in personal injuries or damage to machines. Please secure all drive components prior to disassembly.

- Loosen all clamping screws evenly in sequence and unscrew them.
- Screw the clamping screws into the draw-off thread of the outer pressure ring (component 1) (see image 4).
- Tighten clamping screws crosswise and evenly with a  $\frac{1}{4}$ -turn. Increase loosening torque gradually until the outer pressure ring (component 1) and the outer ring (component 2) are separated.
- Screw clamping screws into the draw-off thread of the outer ring (component 3) (see image 5).
- Tighten clamping screws crosswise and evenly with a  $\frac{1}{4}$ -turn. Increase loosening torque gradually until the inner pressure ring (component 2) and the outer ring (component 3) are separated.
- Remove the loosened locking device between shaft and hub.

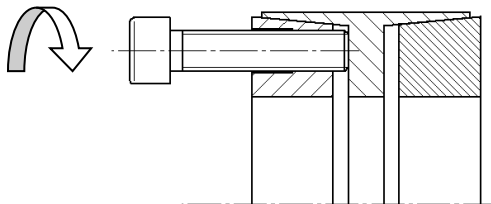

Image 4) Loosening the outer pressure ring

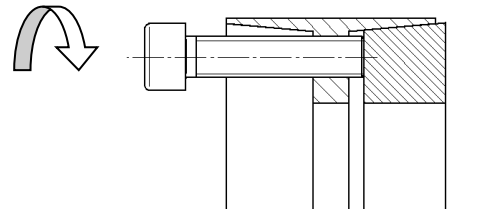

Image 5) Loosening the inner pressure ring



**Attention!**

Non-observance of these instructions or non-consideration of operating conditions selecting the locking device may impair the function.

**Disposal:** Defective locking devices must be cleaned and scrapped.